

1. GENERAL DESCRIPTION

5621 V1.1B-Dis a multi-purpose LCD monitor, it is suitable European market. It is designed to support dual/single LVDS which 15-22inch LCD panel.

The main feature of 5621 V1.1B-Dcan support VGA,DVI signal .

2 FEATURES

Below you will find the detailed feature

Video input	PC-RGB	Format	up to 1680*1050@60Hz
		Color	16bit, 24bit, 32bit
	DVI	Format	up to 1680*1050@60Hz
		Operating speed	165MHz
Audio input	PC-RGB	Pc:Earphone input	
Power	Power Requirement	12V	
	To panel	3.3V,5V,12V	
	Manage	Low power consumable mode: standby<3w	
OSD Language	Chinese,English, French , Italian, German, Korean, Russian,Spanish(Option)		
Key Functions	Select/Exit, Menu, Auto, Left, Right		
Audio Output	2*2w (8 Ω)		

Panel Resolutions	Up to 1680*1050@60HZ		
Input	PC-RGB Input	1D-SUB 15PIN terminal blue color	
	PC-RGB Audio Input	1 earphone terminal black color	
	DVI input	1 DVI 24PIN	
Output	To Panel	LVDS 30PIN/2.0 jack	

3 FUNCTION LAYOUT

PICTURE OF LCD CONTROLLER

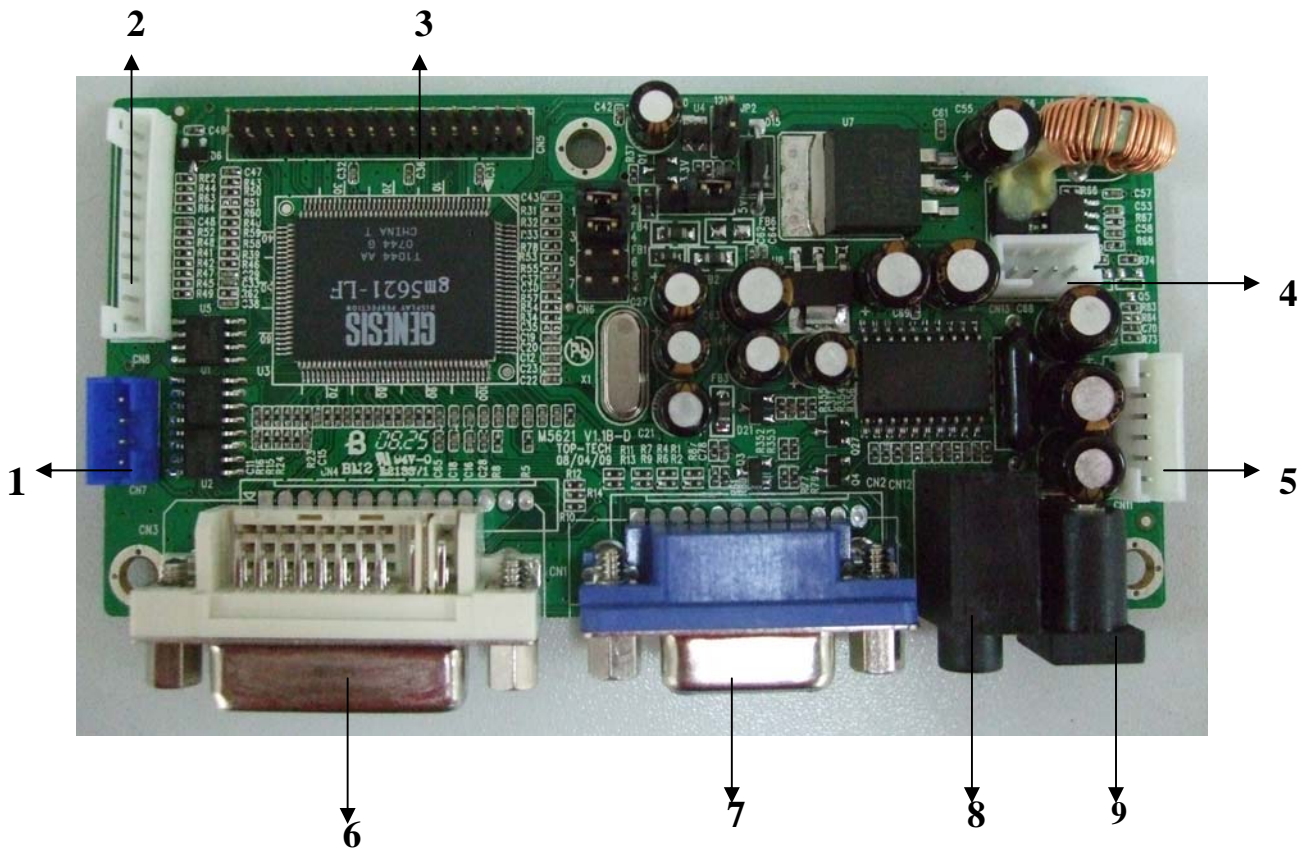

INTERFACE FUNCTION DESCRIPTION

NO	DESCRIPTION	NO	DESCRIPTION
1	DEBUGGING PORT	6	DVI IN
2	KEY BOARD	7	VGA IN
3	LVDS PANEL INTERFACE	8	PC AUDIO IN
4	SPEAKER	9	DC IN
5	INVERTER PORT		

INTERFACE DEFINITION

Below ,please see the symbol and description from left to right pin

CN11 (6PIN/2.0) INVERTER INTERFACE

NO	SYMBOL	DESCRIPTION
1	GND	Ground
2	GND	Ground
3	ADJUST	Brightness adjustment
4	BKLTON	Black-light ON/OFF control
5	12VC	+12V DC Power supply
6	12VC	+12V DC Power supply

CN7(4PIN/2.0) DEBUGGING INTERFACE

NO	SYMBOL	DESCRIPTION
1	5V	+5V Power supply
2	TXD	TXD signal
3	RXD	RXD signal
4	GND	Ground

CN13(4PIN/2.0)SPEAKER

NO	SYMBOL	DESCRIPTION
1	SPK_R	Right audio channel out
2	GND	Ground
3	GND	Ground
4	SPK_L	Left audio channel out

CN8(10PIN/2.0)KEY BOARD+LED

NO	SYMBOL	DESCRIPTION
1	SELECT/EXIT	Select or exit key
2	MENU	Menu key
3	AUTO	Auto key
4	LEFT	Left key
5	RIGHT	Right key
6	GND	Ground
7	GREEN_LED	Green led
8	RED_LED	Red led
9	ON/OFF	ON/OFF key
10	V/D	NC

CN16(2*15PIN/2.0)LVDS PANEL INTERFACE

NO	SYMBOL	DESCRIPTION
1	VDD	Power for panel
2	VDD	Power for panel
3	VDD	Power for panel
4	GND	Ground
5	GND	Ground
6	GND	Ground
7	O0-	LVDS 0DD 0- Signal
8	O0+	LVDS 0DD 0+ Signal
9	O1-	LVDS 0DD 1- Signal
10	O1+	LVDS 0DD 1+ Signal
11	O2-	LVDS 0DD 2- Signal
12	O2+	LVDS 0DD 2+ Signal
13	GND	Ground
14	GND	Ground

15	OC-	LVDS 0DD Clock- Signal
16	OC+	LVDS 0DD Clock+ Signal
17	O3-	LVDS 0DD 3- Signal
18	O3+	LVDS 0DD 3+ Signal
19	E0-	LVDS EVEN 0- Signal
20	E0+	LVDS EVEN 0+ Signal
21	E1-	LVDS EVEN 1- Signal
22	E1+	LVDS EVEN 1+ Signal
23	E2-	LVDS EVEN 2- Signal
24	E2+	LVDS EVEN 2+ Signal
25	GND	Ground
26	GND	Ground
27	EC-	LVDS EVEN Clock- Signal
28	EC+	LVDS EVEN Clock+ Signal
29	E3-	LVDS EVEN 3- Signal
30	E3+	LVDS EVEN 3+ Signal

4.CONTROLLER DIMENSIONS

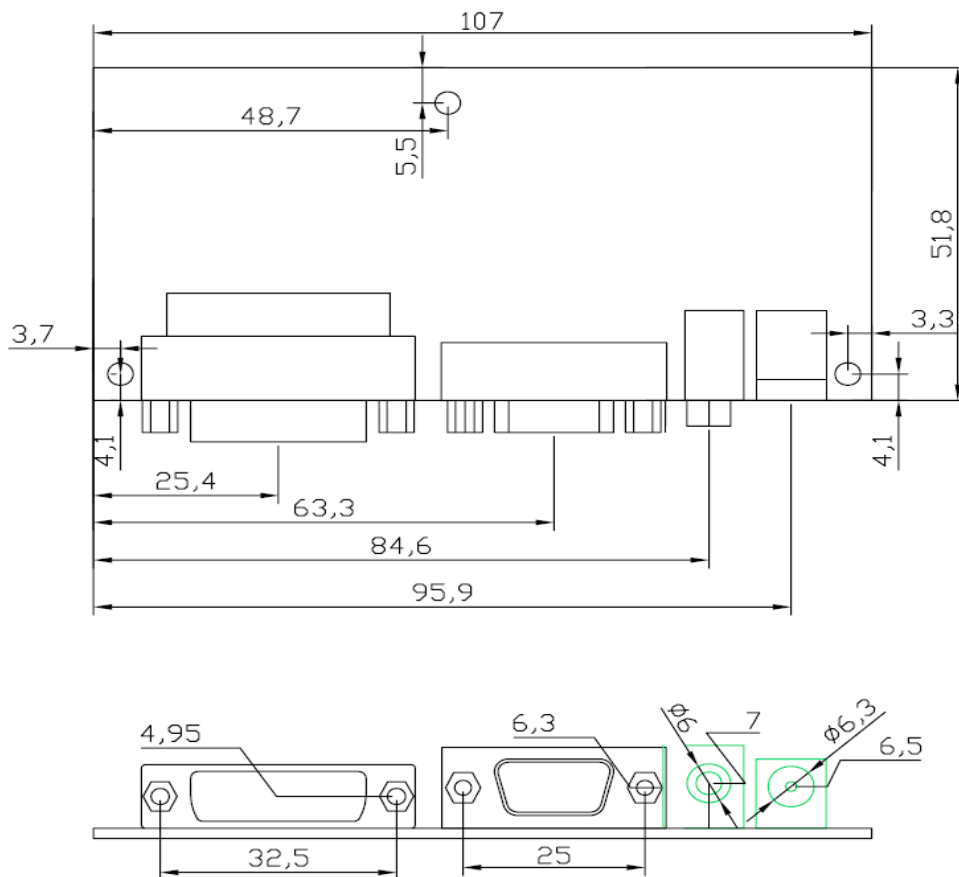

5. KEY BOARD +LED SYSTEM SCHEMATIC



6. OPERATION REQUIREMENT

Do not pressed and distorted.

Keep away from static and water.

Relative humidity : $\leq 80\%$

Storage temperature:-10~+60°C

Operation temperature:0~+40°C